

The GO-24V Arduino-MKR compatible shield

An MKR shield with 4 digital inputs, 4 digital outputs and 2 analog inputs, all rated 24V.

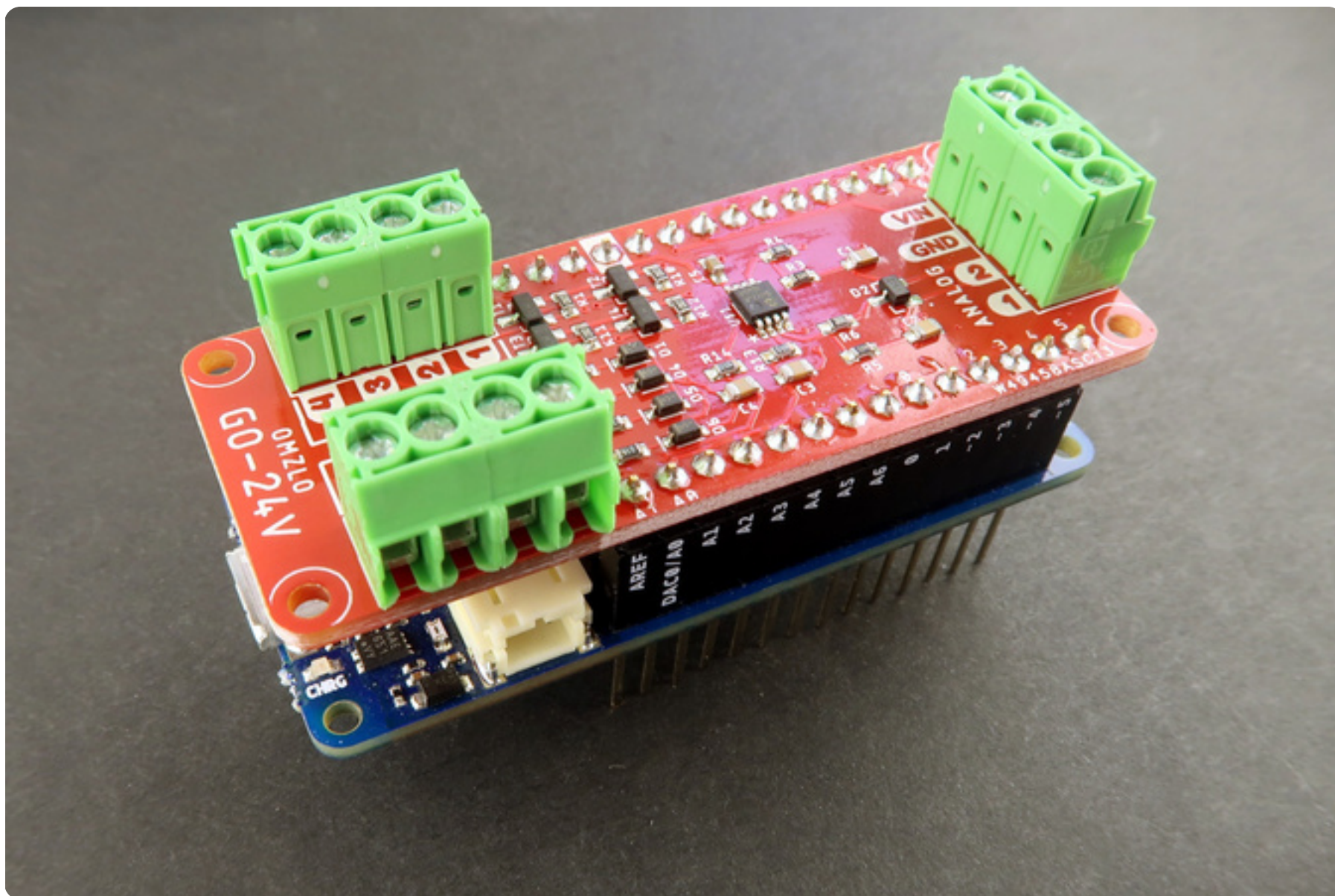

Nowadays, most common microcontroller operate with 3.3V logic, while the older classic Arduino UNO uses 5V logic, but sometimes you want to connect your project to 12V or 24V gadgets, which are common in automation and home systems.

We created the **GO-24V MKR shield** with 24V tolerant inputs and outputs exactly for this purpose. Just connect it to any board with the Arduino-MKR form factor and go!

Description

The Omzlo **GO-24V MKR shield** is designed to fit on top of [Arduino MKR](#) compatible boards, such as the Arduino MKR Zero. But it really shines as part of an [IoT project](#) on top of a [Omzlo CANZERO](#) node.

It features:

- 4 digital inputs (0-24V).
- 4 digital open-drain outputs (0-24V), sinking up to 2A.
- 2 analog inputs (0-24V).

The shield also breaks out the GND and VIN pins of the MKR board.

Details

The following table provides details of the shield input/output capabilities:

Shield connector	Arduino MKR Pin	Characteristics
Sink 1 (Output)	D0	0-24V (max 60V, 3.1A)
Sink 2 (Output)	D1	0-24V (max 60V, 3.1A)
Sink 3 (Output)	D2	0-24V (max 60V, 3.1A)
Sink 4 (Output)	D3	0-24V (max 60V, 3.1A)
Input 1	D4	0-24V
Input 2	D5	0-24V
Input 3	D6	0-24V
Input 4	D7	0-24V
Analog in 1	A0	0-24V mapped to 0-3.2V
Analog in 2	A1	0-24V mapped to 0-3.2V
GND	GND	-
VIN	VIN	-

Note that this shield does not feature isolated inputs/outputs (e.g. using optocouplers) or galvanic isolation.

The **digital inputs** have the same shifting characteristic as the GPIO of the MCUs they are connected

to. For a SAMD21 board like the Arduino MKR Zero or the Omzlo CANZERO, this means that any input below 1V will be considered LOW (0), and any input above 1.8V will be considered as HIGH (1).

The digital outputs are **sinking outputs**, which means that they are used to switch loads on the low side, as shown in the picture below.

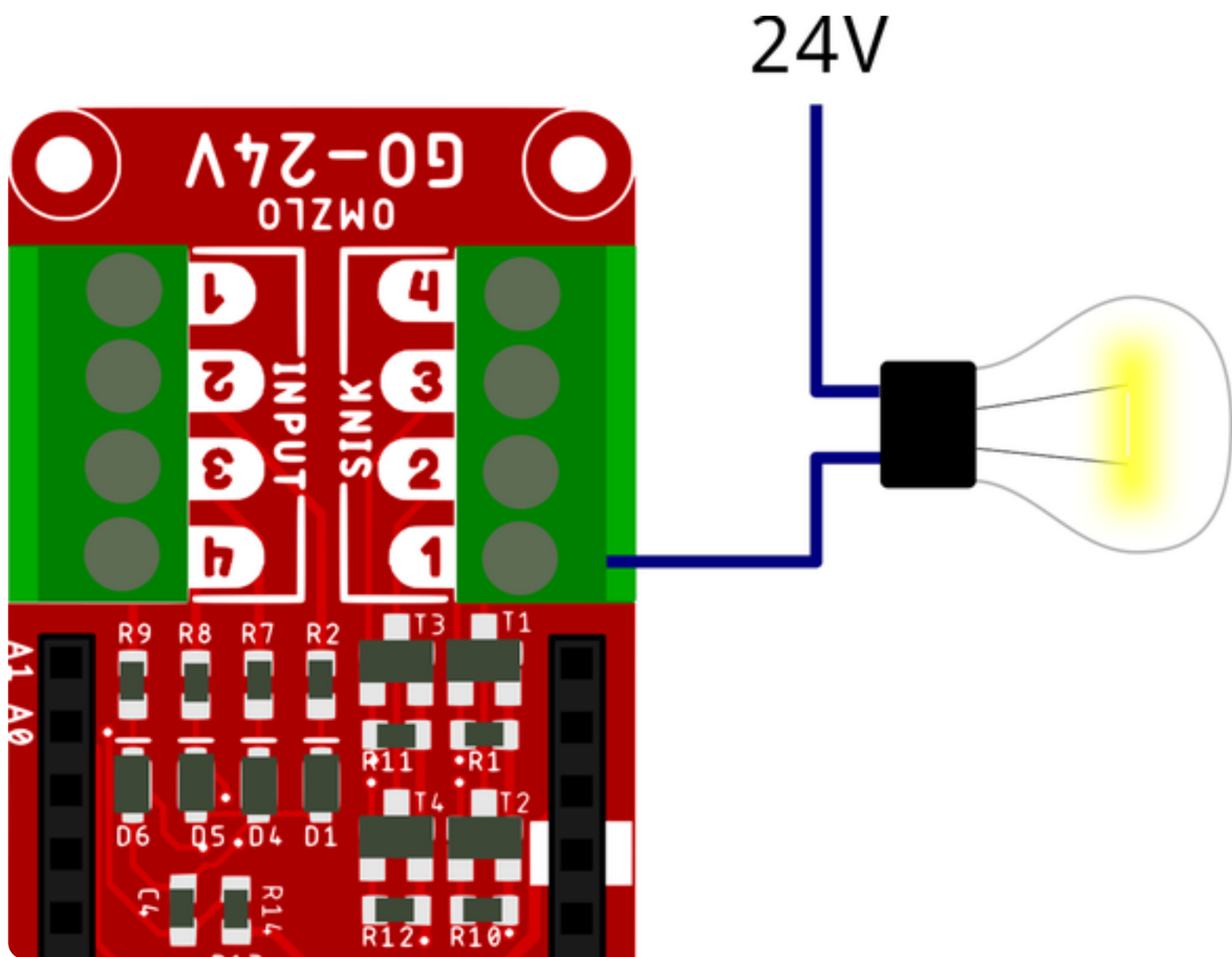

The **sinking outputs** are controlled by MOSFETs, which have a comfortable maximum 3.1A current rating. In practice, it's best to keep safely away from those limits. We tested currents up to 1.5A without any issue, low-side switching power LEDs. Lower currents should also be considered when switching these MOSFETs very rapidly (e.g. through fast PWM). In doubt, please consult the safe operating area of the MOSFET in the [datasheet](#).

Analog inputs are managed by feeding input voltage in a voltage divider and a buffering op-amp, resulting in a scaled voltage range where 24V corresponds to 3.2V on the analog input of the Arduino-compatible board (and 24.75V corresponds to 3.3V). In terms of accuracy, the voltage divider uses 1% resistors, but the greatest source of inaccuracy can come from the ADC of the MCU itself. It is possible to apply [calibration](#) to each board to substantially increase accuracy.

Arduino code

Reading the digital input is as simple as reading any ordinary digital input:

```
#define IN1 4
...
pinMode(IN1);
...
input = digitalRead(IN1);
```

Using the sinking output is similarly simple:

```
#define SINK1 0
...
pinMode(SINK1);
...
digitalWrite(SINK1, HIGH);
```

Using the analog input is a bit more complex since voltages need to be scaled to match the input range. For a 12-bit analog input, the values returned by `analogRead()` will range from 0 to 4095, where 4095 corresponds to 24.75V using the default internal analog reference and assuming everything is perfectly calibrated (An analog input of 3971 should correspond to 24V).

```
void setup() {
  analogReadResolution(12);
}

void loop() {
  int a;
  float voltage;
  ...
  a = analogRead(A1);
  voltage = (24.75*((float)a))/4095.0;
  ...
}
```

Notes:

- By default Arduino is configured to perform 8-bit analog readings. The function [analogReadResolution\(\)](#) can be used to change this to 12 bits on supported boards featuring the SAMD21G18 MCU.
- You should expect a few percents of inaccuracy in the reading due to the 1% tolerance of the resistors and because of the ADC itself. Calibration can be used to fix this issue.

What's included

As shown in the picture below, the Omzlo **GO-24V MKR shield** comes as a shield with the following **unsoldered** headers:

- One breakable male 2.54mm pin headers (0.1")
- Three 4-pin 3.5mm terminal blocks (colors may vary).

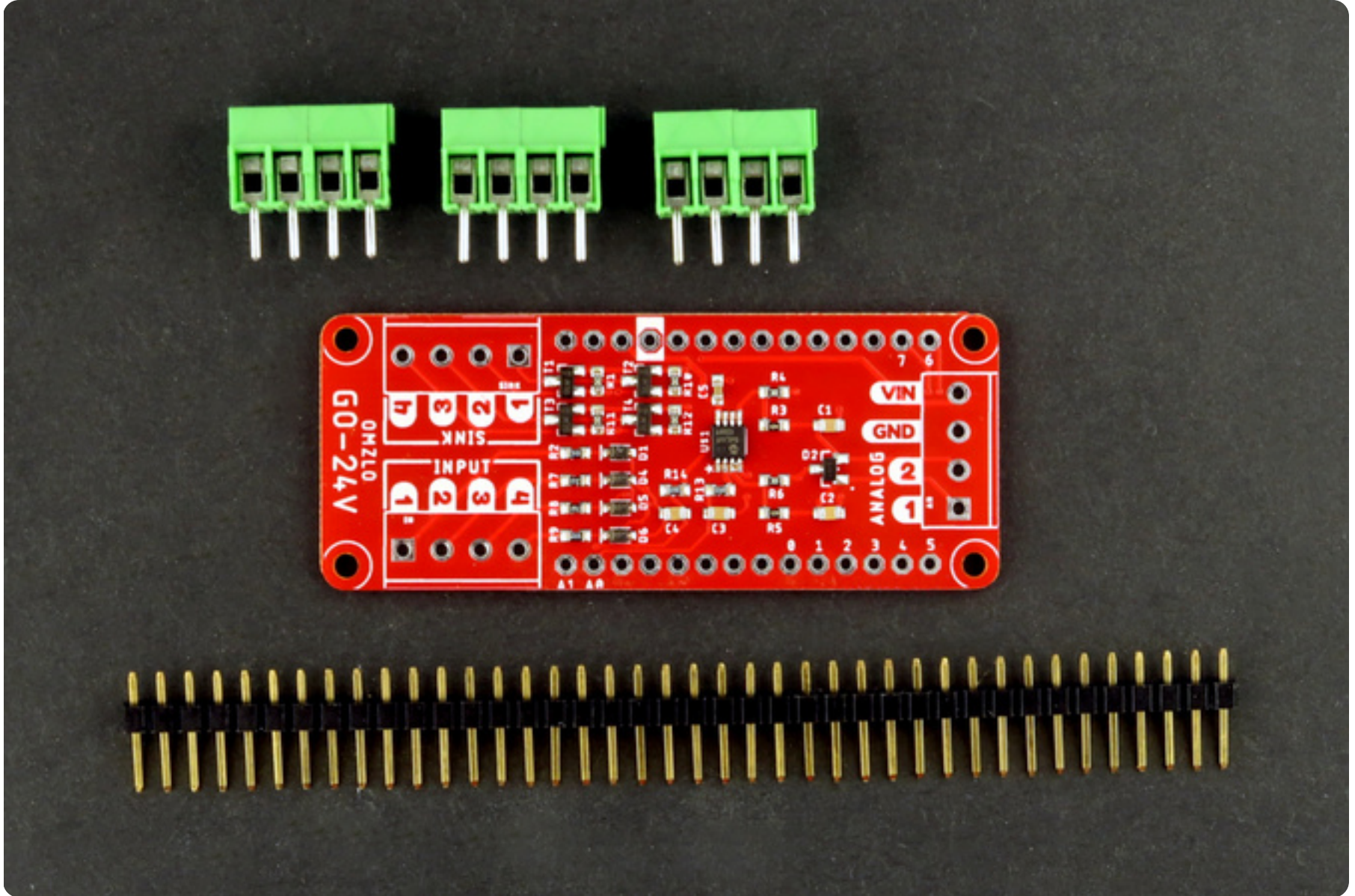

Resources

- [Board schematics](#).
- Eagle CAD design files [pending].

The GO-24V Arduino-MKR compatible shield is available on [our online shop](#) and on [Tindie](#).

Comments

2 comments triggered our SPAM filter and will be reviewed before publication.

Leave a comment

You can use a subset of markdown here: links, images and html are disabled however.

POST COMMENT

INFORMATION

About Omzlo P.C.

FOLLOW US



(c) Omzlo P.C. 2020 