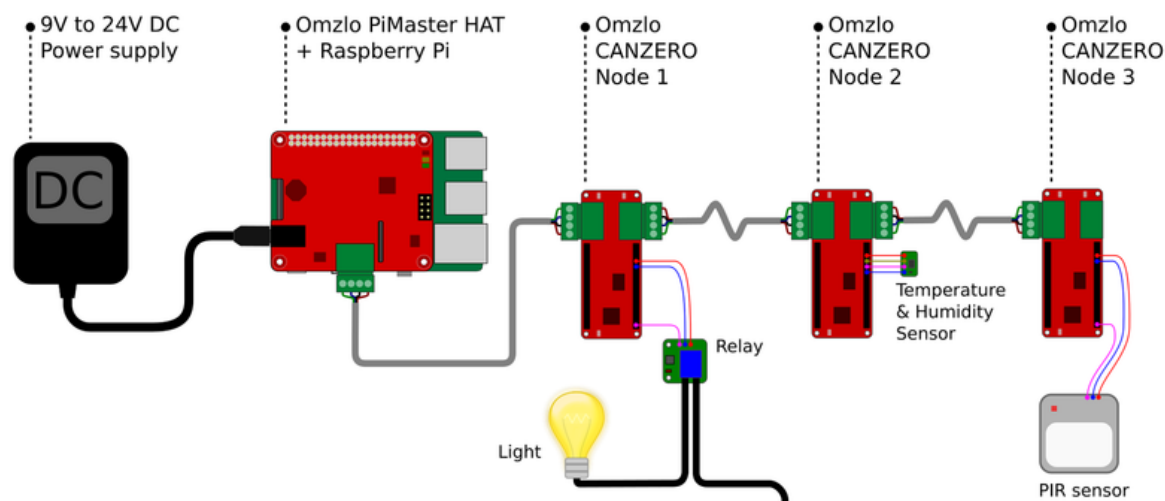

omzlo

[SHOP](#)[BLOG](#)[DOCUMENTATION](#)[FORUMS](#)

The NoCAN platform

Build your own internet of things for the home and the garden.

[WATCH THE VIDEO](#)

About NoCAN

The NoCan IoT platform enables the creation of a very reliable wired network

composed of Arduino-compatible nodes connected through CAN bus, targeting application domains where wireless approaches are not satisfactory. Each node features a 32-bit ARM cortex microcontroller (SAMD21G18) and the network is managed by a Raspberry-Pi.

You can control your network with the command line, a smartphone, a browser, MQTT or JSON/REST! And of course, NoCAN is open-hardware so you can incorporate in your own design without any restrictions. [Read more about the NoCAN platform](#) or watch our [Kickstarter video](#).

READ MORE ABOUT THE NOCAN PLATFORM

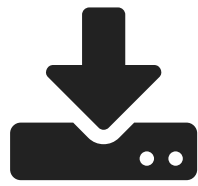

Getting started

You just bought [NoCAN hardware](#) and you don't know where to start? Have no fear! We got you covered with our [big installation tutorial](#).

And if you can't figure something out, come and ask for help on our [Forums](#).

INSTALLATION TUTORIAL



Arduino developpement

Once you have configured your Arduino environment to use the [NoCAN board definitions](#), as described [in the Arduino section](#) of our tutorial. You can:

- [First, check the Arduino NoCAN library documentation](#)
- [Read our PIR sensor tutorial](#)
- [Learn how to build an automated plant watering system.](#)
- Look at some sample code for:
 - [Connecting an LCD display.](#)

- [Controlling a relay.](#)
- [Collecting temperature data from a DS18B20.](#)
- [Connecting a BME280 Atmospheric Sensor.](#)
- [Creating a realtime clock \(RTC\) with a CANZERO.](#)
- [Connecting an Adafruit RA8875 graphics driver board.](#)

You will also want to check out the [pinout diagram of the Omzlo CANZERO.](#)

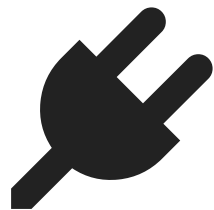

Interfaces: CLI, Blynk, MQTT, REST, the web, etc.

NoCAN is a strongly interoperable platform that does not rely on any "proprietary cloud" to stay alive. Our command line utility [nocanc](#) allows controlling your network from a Linux machine, a Windows PC or a Mac. Learn to:

- [Control your NoCAN network from your smartphone with blynk](#)
- [Use MQTT to connect NoCAN to IoT platforms](#) such as or
- [Control your network with a simple web browser.](#)
- Control your network with a RESTful JSON API (coming soon)
- Make your own interface with [the NoCAN event protocol over TCP/IP](#)
- Look at the low level [CAN bus protocol](#)

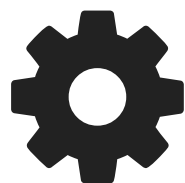

Hardware

Check out the following links for detailed information about our hardware and the firmware that powers it:

- [The CANZERO node hardware description](#), featuring a 32-bit SAMD21, an STM32F0, Arduino-MKR form-factor, ...

- [The PiMaster HAT](#), the HAT that powers your Raspberry-Pi and your network (it also works with the [BalenaFin](#)).
- [SAM21 firmware source code for the CANZERO](#) and [SMT32F0 CANbus driver firmware source code](#).
- [STM32F0 firmware source code for the PiMaster](#)
- [CANZERO Eagle CAD design files](#) and [PiMaster Eagle CAD design files](#)

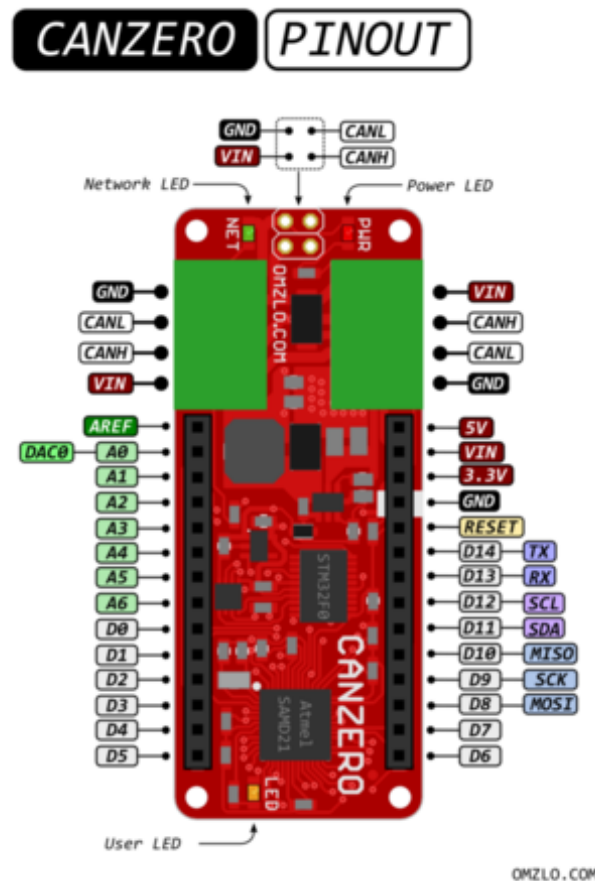

Unless otherwise indicated, all hardware design files are licensed under [CC BY-SA 4.0](#) and all software is licensed under MIT.



Get it now!

You can find the [Omzlo CANZERO](#) and the [Omzlo PiMaster](#) on our [Online store](#).

Comments

Did you guys look at the CANOpen specification at all? It handles a few of the things that you're attempting to solve...

Alwyn Nixon-Lloyd, about 2 years ago

@Alwyn Nixon-Lloyd. Using an existing standard (like CANOpen) is always better than creating a new solution from scratch. However, I don't think CANOpen offers any form of dynamic address allocation. I don't believe that it offers firmware update over the network. In general, CANOpen is quite complex and not necessarily the ideal tool for the maker community we are targetting.

Omzlo, about 2 years ago

Hi,

I just found your project, it seems to be perfect for an experimental project I want to build. But realized you've already closed the funding on Kickstarter...

Is there another way to pitch in and get a Nocan kit?

Thanks Karen

Karen Gabrielyan, almost 2 years ago

I find this project very fascinating, as I've been doing some research into IoT tech and want to get myself involved into building a small automated garden experiment. I'm looking forward to be able to purchase the kit and get myself into it, unfortunately only found out about it after the kickstarter campaign finished. Coming from 100% software background here, let's hope that hardware doesn't get me too overwhelmed.

Question: Are there any ideas for making a golang library for nocanc, besides the Arduino & cli tool? I'd like to be able to bridge it with <https://www.flogo.io/> which looks like it can be a very powerful combination.

Konstantin Indjov, almost 2 years ago

Thanks for great work with NoCAN. Thanks for publishing this material.

NoCAN looks very easy to use and the fact that is compatible with many Arduino compatible boards make it even more exiting.

Also, thanks for the work with Blynk. Just one word, AWESOME!!

ME, over 1 year ago

@ME: thanks for the kind words! It gives us plenty of motivation!

Omzlo, over 1 year ago

I like your idea of this protocol its fascinating and really great. Especially considering the ability to remotely upload code to nodes, and having everything connected to a single endpoint. Must the nodes be connected in daisy chain form, or can some sort of hub be created or allowed that allows for all nodes to be connected to a single point? I am a heavy MQTT user, but it seems you don't support certificates authentication over MQTT. If one was to start building products on your protocol, being new what are the chances of not going bursts and lack of support in the future?

Odianosen Ejale, about 1 year ago

@Odianosen Ejale, To answer your questions: - For optimal communications, the nodes must be connected in a daisy chain, but other approaches may be possible, see <https://www.omzlo.com/faq>
- We plan to implement enhanced security options for MQTT in the near future, starting with TLS. - Yes, omzlo is a startup and there's always a risk that we will fail. But the good thing is that we are open-source/open-hardware so anybody can continue our work.

Omzlo, about 1 year ago

希望能够很方便的接入homeassistant, 这样它将能够与更多的设备进行互动。

allen.shen, 12 months ago

CANOpen handles dynamic addressing, firmware update over the network, proper master/slave specifications, device profiles, and has been around for roughly 20 years...

Geoffrey Van Landeghem, 9 months ago

Leave a comment

You can use a subset of markdown here: links, images and html are disabled however.

INFORMATION

[About Omzlo P.C.](#)

FOLLOW US



(c) Omzlo P.C. 2020